

A Centenary Celebration

Designed By Dorothy Baker for Lecien

To celebrate the 20th anniversary of Yoko Saito's Centenary Collection

48½" x 48½"

Machine Quilted by Irene Brayne, Braynewaves Quilting of Oakville Ontario



To view more Dorothy Baker Designs visit her at <http://dorothybakerdesigns.blogspot.ca/>

To view Lecien's Centenary XX & Archive collections and to download Dorothy Baker's free pattern
Please visit <http://www.lecien.co.jp/en/hobby/>

LECIEN

A Centenary Celebration

Designed By Dorothy Baker

The following is a list of the fabric requirements.

Background

1 Meter (1 ⅛ Yds) - I used Lecien's Centenary XX Collection #30912-90

Border:

1 Meter (1 ⅛ Yds) - I used Lecien's Centenary XX Collection #30910-10

Outer Circle & Binding

1.1 meters (1¼ Yds) - I used Lecien's Centenary XX Collection #30918-01 (the reverse side)

Middle Circle:

.4 meter (½ Yd) - I used Lecien's Centenary XX Collection #30913-90

Inner Circle

.4 meter (½ Yd) - I used Lecien's Centenary XX Collection #30911-10

Border Applique

.75 Meter (¾ Yd) - I used Lecien's Centenary XX Collection #30914-80

Circles & Scallops

An assortment of fat quarters and fat eighths from Lecien's Centenary XX & Archive Collections

.....

LECIEN

A Centenary Celebration

Designed By Dorothy Baker

Applique Instructions

Please read all the directions through carefully before beginning. 100% Cotton Fabrics have been used throughout the quilt.

I prefer to prewash and iron all my fabrics before beginning a new project, particularly to check for colorfastness.

The block measurements given are finished measurements, remember to add at least ½ inch for your seam allowance. I always add 1 inch, in case my appliqué stitches shrink my block, and trim after the freezer paper is removed. For example, the finished Measurement of the background is 38" x 38", I cut my background fabric 39" x 39", and then trim to 38½" x 38½" after the appliqué is completed. All seam allowances used throughout the quilt are ¼ inch.

I have always used the freezer paper method of appliqué, but feel free to use whatever method you are comfortable with. Trace the appliqué shapes, from the master pattern, onto the **shiny** side of the freezer paper. Mark the placement order of the pieces onto the **dull** side of the freezer paper, as per the master pattern. This will help you identify where each shape should be placed on your block. Also it is helpful to mark any edges that are overlapped by another piece with a broken line - - - -. I have marked some of these on the master patterns, but not all.

Cut out the freezer paper shapes and iron them, shiny side down, to the wrong side of the chosen fabric, using a dry iron, on the cotton setting. If you place the freezer paper templates so that the edges are on the bias of your chosen fabric it will make the turning of them easier, particularly with curved edges. Cut out your appliqué shapes, allowing a scant ¼ inch seam allowance.

Using a water-soluble, **acid-free** glue stick, glue around the outside edges of your freezer paper. Turn under the seam allowance onto this glued edge, being careful to have a nice smooth edge. Clip the seam allowance only when necessary. **Remember: Do not** turn under the seam allowance on the edges marked with the broken line, so that it may be tucked under the piece that overlaps it. Trace the master pattern onto the background fabric using a water soluble marker. Glue the prepared shapes onto the background fabric. You may stitch each piece as you go or you may prefer to build the entire block before you sew.

Using a fine appliqué needle (I use a #10) and thread matching the colour of your appliqué fabric, sew shapes in place. Take tiny stitches that just catch the edge of the shape and then go directly down to the wrong side of your background fabric. Bring the needle up again, about 1/8 inch away from your first stitch, catching the edge of the shape, then go directly down into the background fabric again, and so on. Pull your thread **slightly**, every five or six stitches, to tighten them. When sewing one shape onto the top of another shape, **do not** go down through the background fabric, try to sew only to the fabric that is directly under it.

When everything has been sewn, **carefully** make a slit behind each shape. Soak the block in warm water for 1 or 2 minutes, reach in through the slit and pull out the freezer paper. It may be helpful to use tweezers for this. When there is a shape on top of a shape, remove the paper from the bottom layer, then make a slit in the next layer and remove the paper. Rinse the block well to ensure all the glue has been removed.

I find it best to dry the block before ironing, as sometimes pressing a fabric while still damp will trigger bleeding. You may or may not cut away the background fabric under your appliqué, leaving a ¼ inch seam allowance all around, depending on your preference.

LECIEN

©2014 Dorothy Baker, All Rights Reserved

A Centenary Celebration

Designed By Dorothy Baker

Directions

CAUTION: Before printing these patterns, please ensure you have turned off Page Scaling on your Printer. Failure to do this will result in incorrect measurements

This pattern, before borders, measures 38" square, not including seam allowances. The master pattern provided is for one quarter of the design. If desired, print and assemble each section 4 times, as per *diagram A*

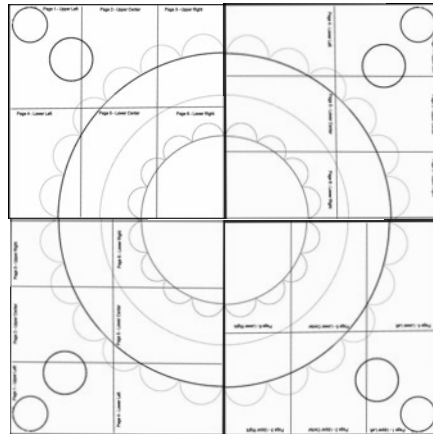

Diagram A

Step 1

Cut background fabric 39½" x 39½".

Step 2

Referring to *Diagram B*, applique scallops 2A - 2F to each quarter of the background fabric.

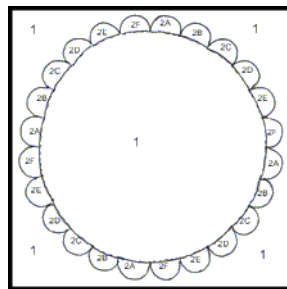

Diagram B

Step 3

Using the master pattern as your guide, cut four freezer paper templates for Circle 3 and four freezer paper templates for Circle 4.

Iron the freezer paper templates to the wrong side of your chosen fabrics. Cut out leaving a ¼" seam allowance on all sides. See *Diagram C*

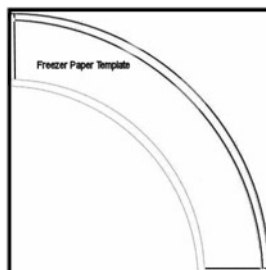

Diagram C

A Centenary Celebration

Designed By Dorothy Baker

Directions - Page 2

Step 3 Cont'd

Using a 1/4" seam allowance, sew the 4 sections of Circle 3 together to form a circle. Repeat for Circle 4. See *Diagram D* and *Diagram E*

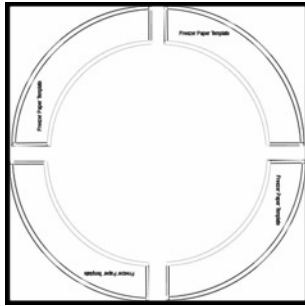

Diagram D

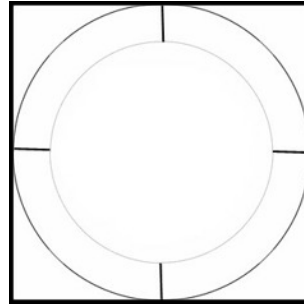

Diagram E

Step 4

Refer to *Diagram F*, turn under the outside edge of Circle 3 and applique on top of Scallops 2A - 2F.

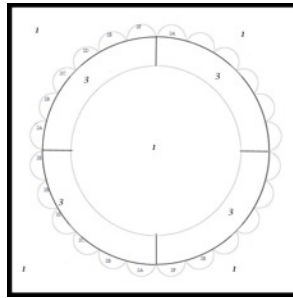

Diagram F

Step 5

Refer to *Diagram G*, turn under the outside edge of Circle 4 and applique on top of Circle 3.

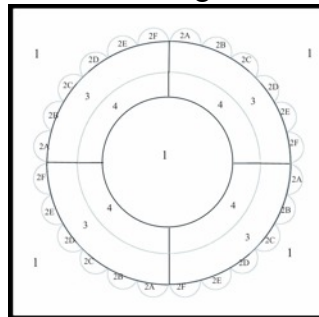

Diagram G

Step 6

Refer to *Diagram H*, applique scallops 5A - 5D on top of each quarter of Circle 4

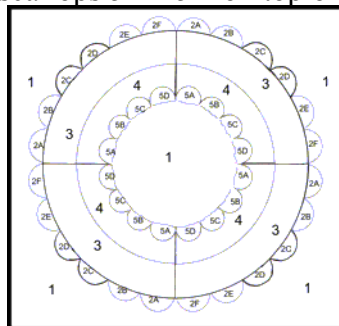

Diagram H

A Centenary Celebration

Designed By Dorothy Baker

Directions - Page 3

Step 7

Assemble the pattern sheets for the Inner Circle applique. Cut a 16" square of the chosen fabric for the inner Circle (Piece 6). Centering the design, applique the circles, 7A - 7H, to this fabric. See *Diagram I* Using a freezer paper template for Circle 6, making sure the diameter is 15", cut out the circle and applique on top of scallops 5A - 5D. Refer to *Diagram J*. If desired, you may cut away the background fabric.

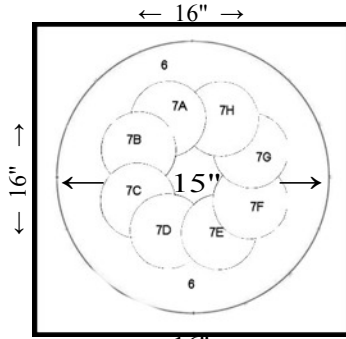

Diagram I

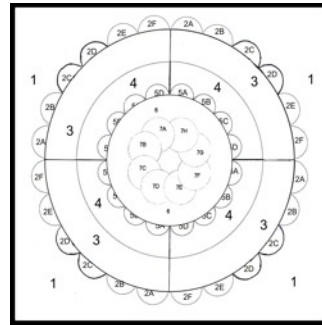

Diagram J

Step 8

Square up your block to measure 38½" x 38½", which includes your seam allowances. Set aside

Step 9

Cut 4 rectangles from your chosen border fabric - 5½" x 38½". Referring to *Diagram K*, applique the borders

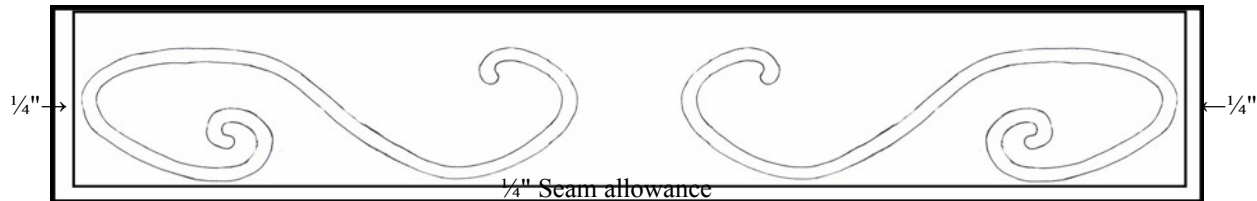

Diagram K

Step 10

Cut 4 - 5½" squares of your chosen border fabric.

Sew one 5 ½" square to each end of 2 border strips. Referring to *Diagram L*, sew the border strips to the quilt.

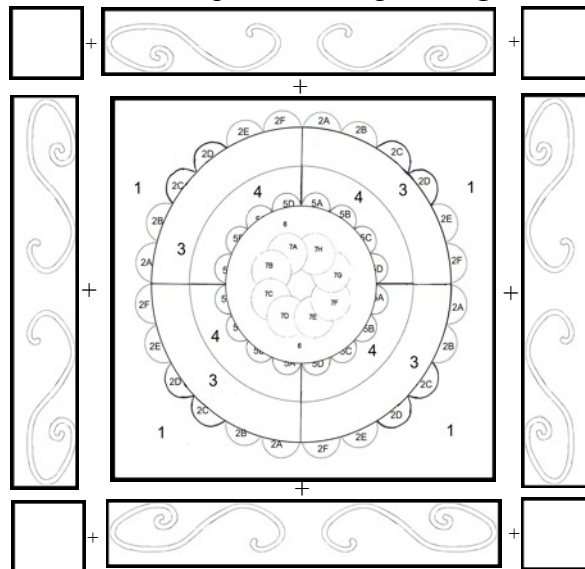

Diagram L

A Centenary Celebration

Designed By Dorothy Baker

Directions - Page 4

Step 11

Referring to *Diagram L*, applique the circles.

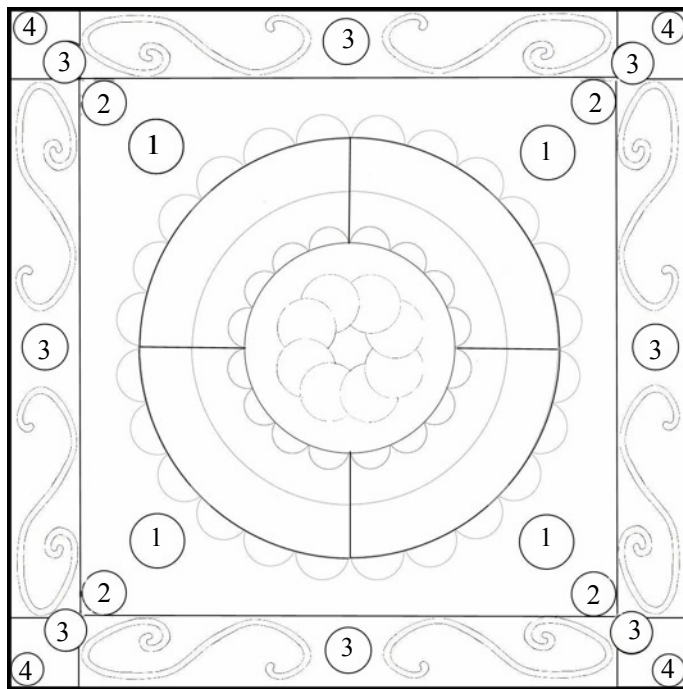

Your quilt top should now measure 48½" x 48½". Quilt as desired.

A Centenary Celebration

Designed By Dorothy Baker

Page 1 - Upper Left

Master Pattern

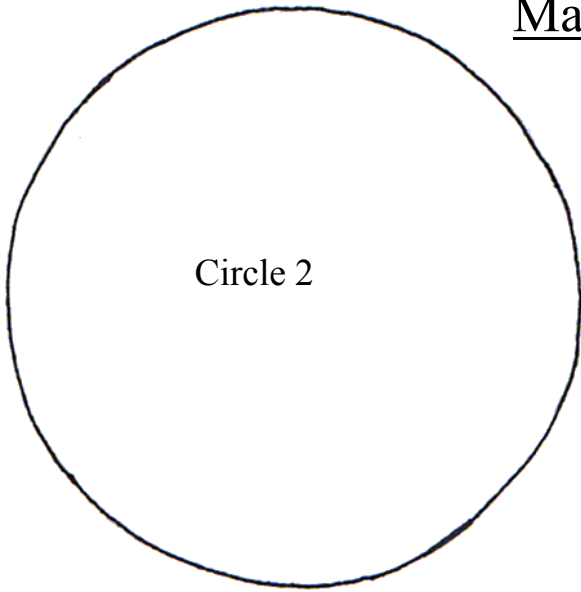

1

LECIEN

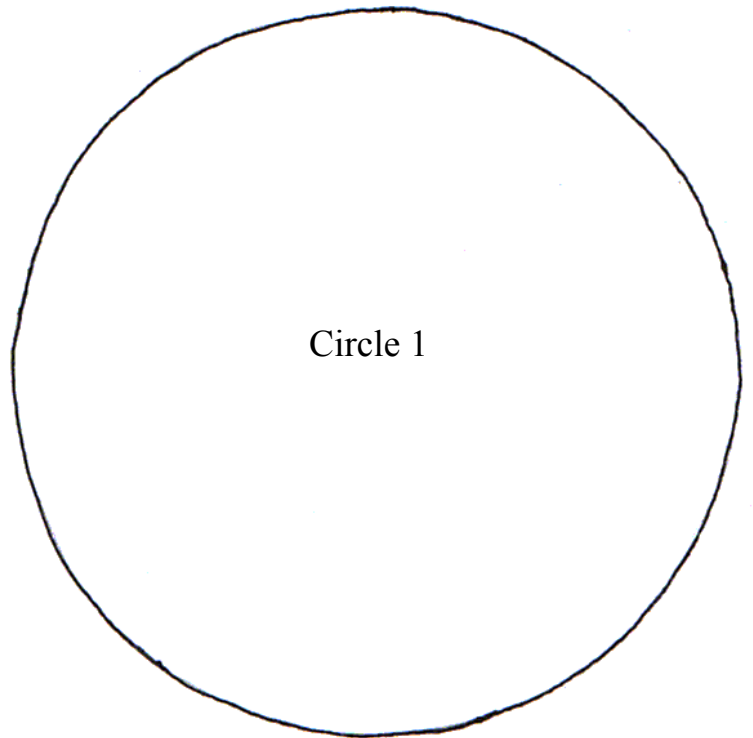

Pattern Assembly

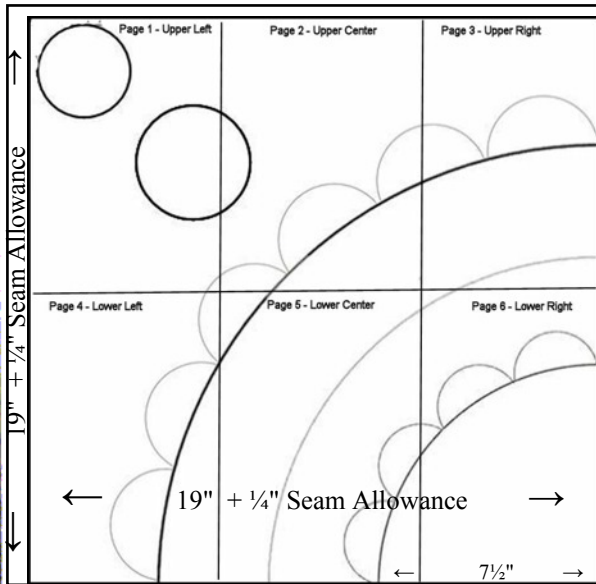

2C

A Centenary Celebration

Designed By Dorothy Baker

Page 2 - Upper Center

LECIEN

Master Pattern

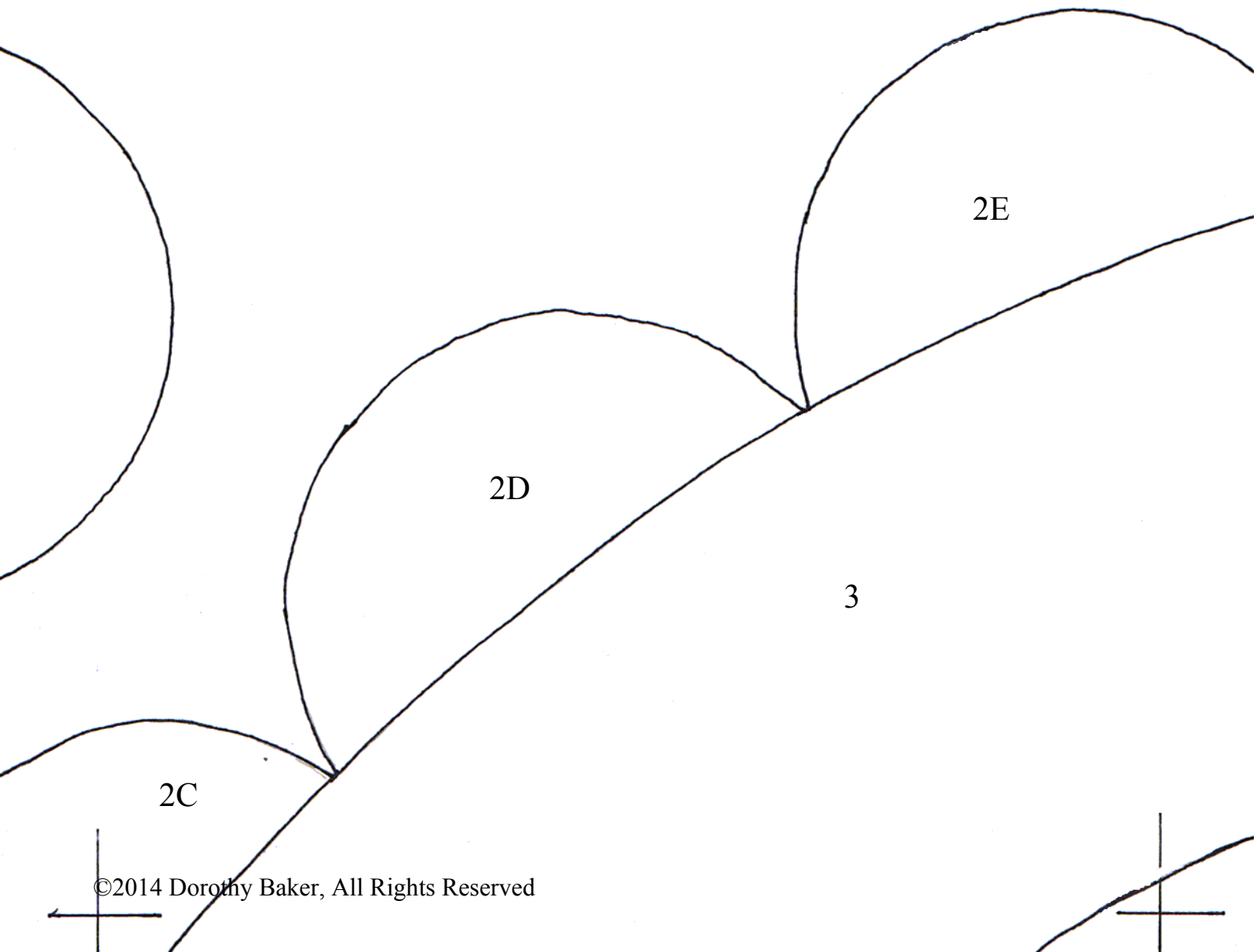

A Centenary Celebration

Designed By Dorothy Baker

Page 3 - Upper Right

Master Pattern

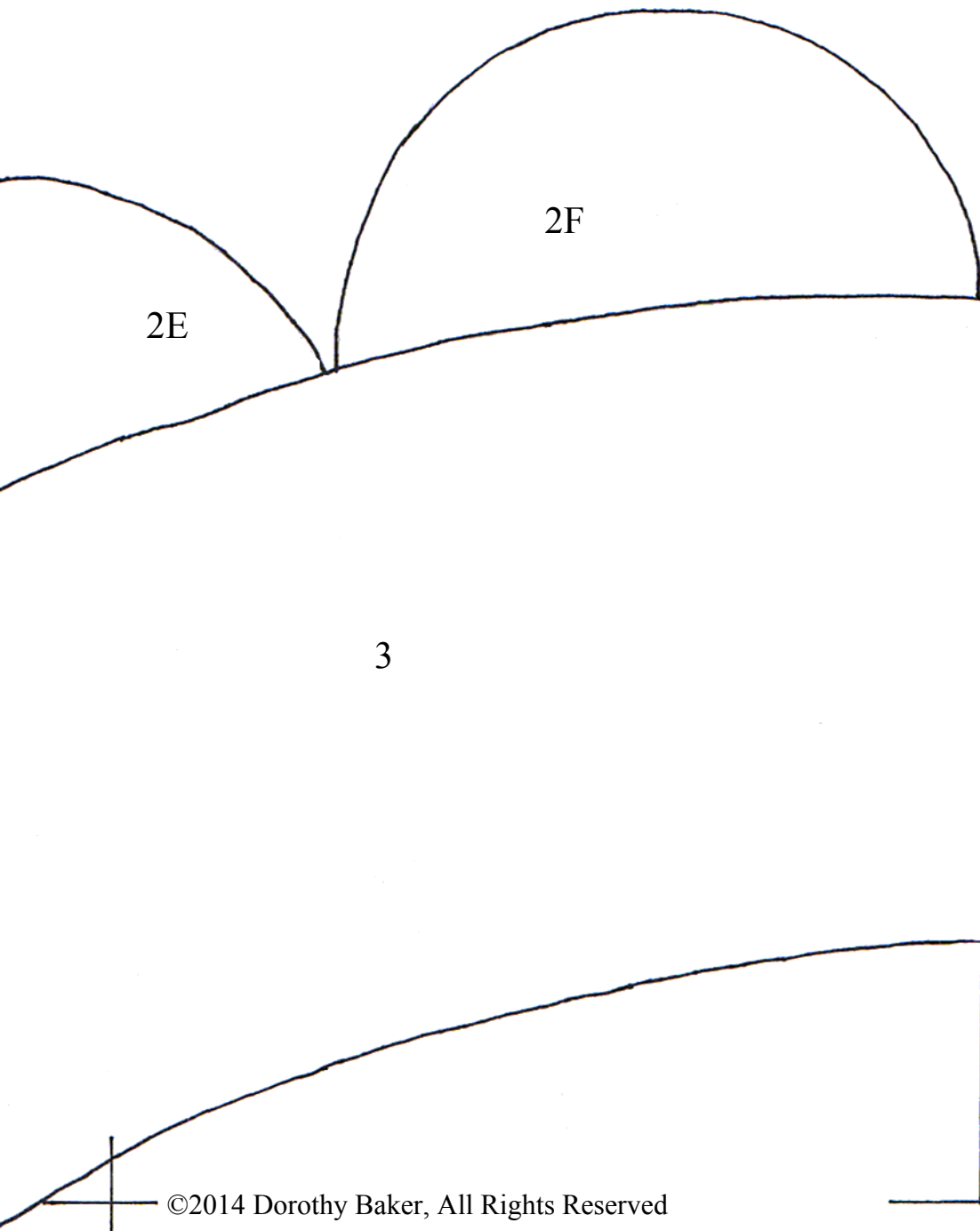

LECIEN

LECIEN

1

2B

2C

3

2A

Master Pattern

A Centenary Celebration

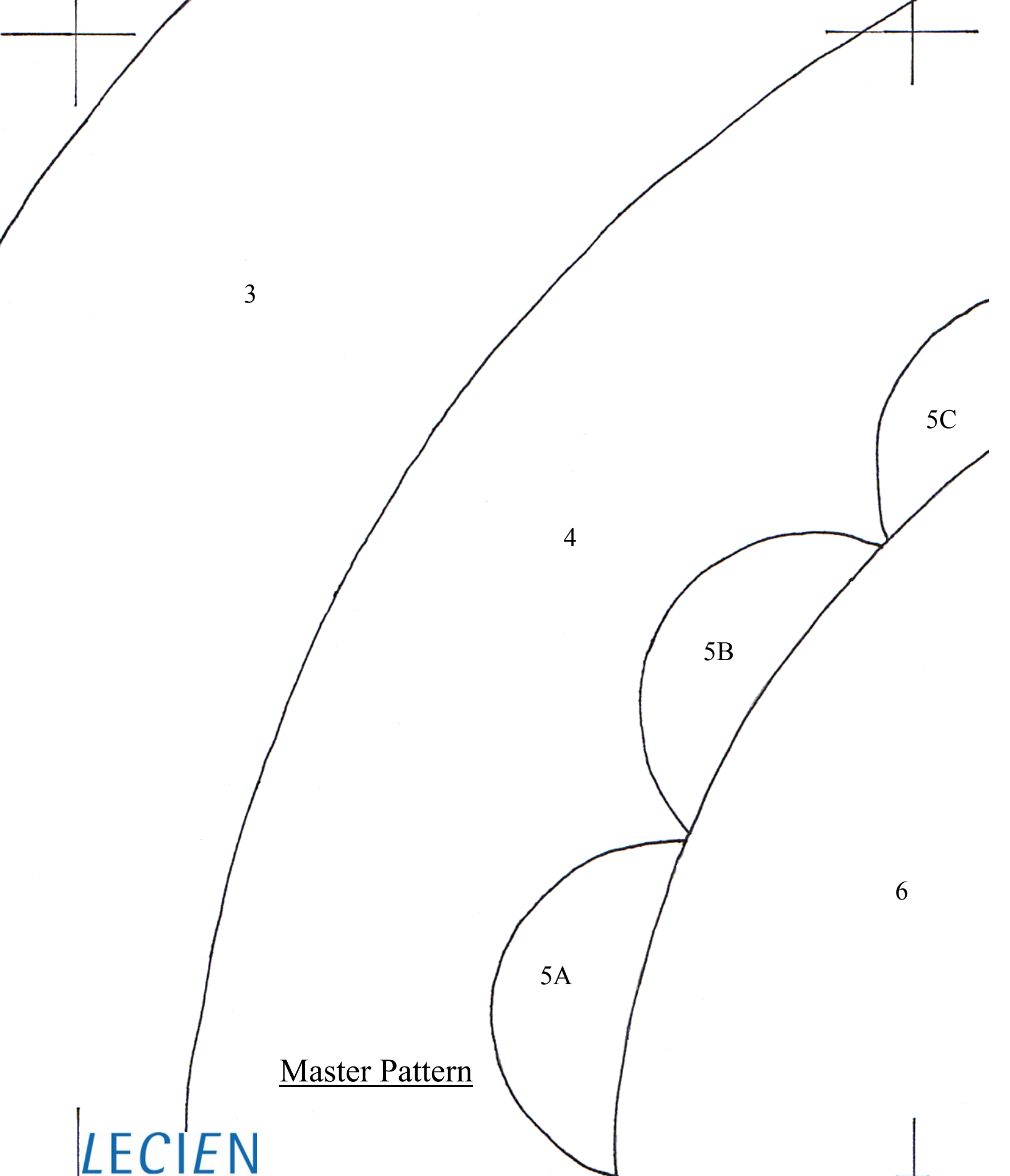

Master Pattern

LECIEN

A Centenary Celebration

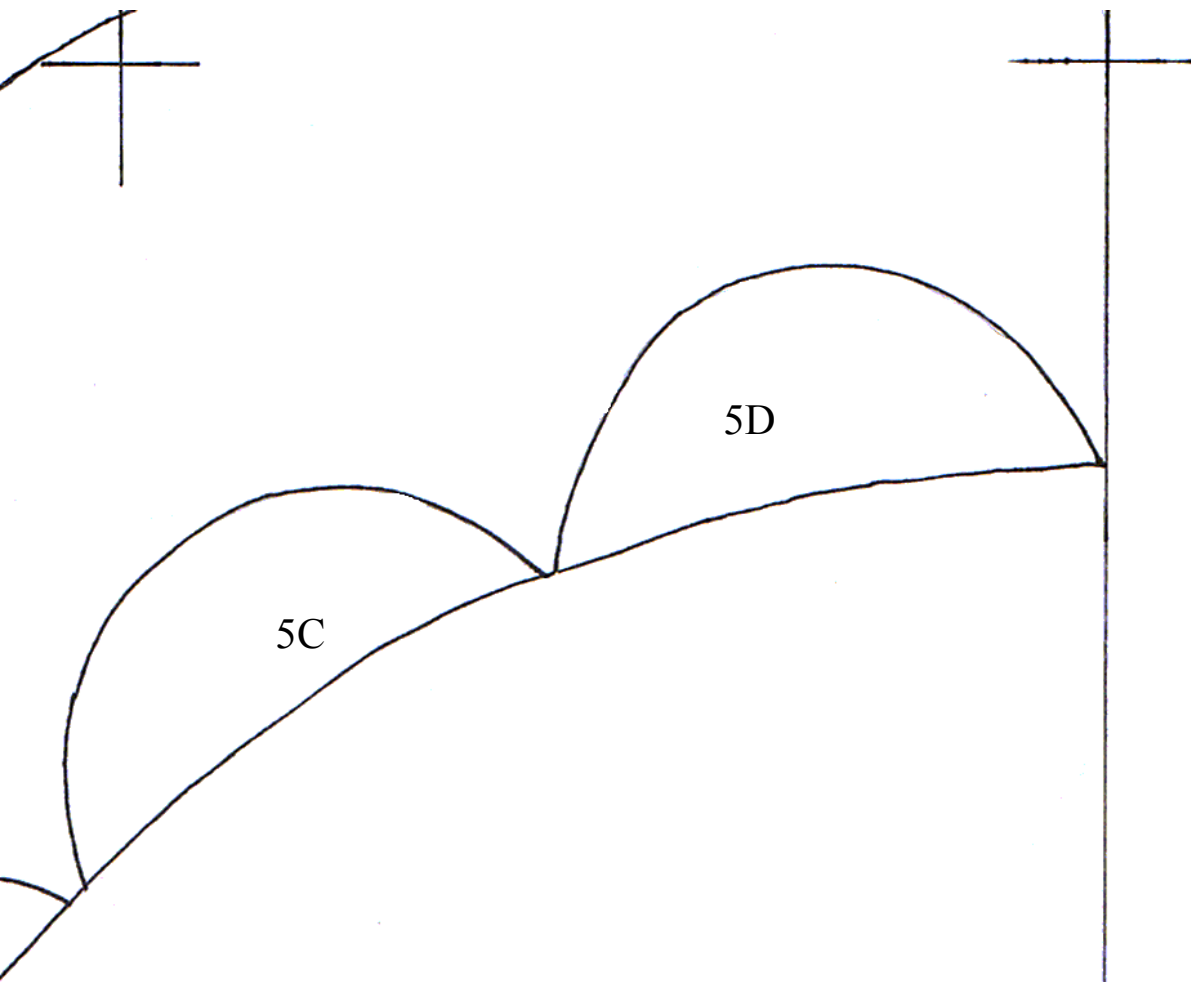

6

*See Separate Pattern sheets for Circle Applique

LECIEN

A Centenary Celebration

Designed By Dorothy Baker

Page 6 - Lower Right

©2014 Dorothy Baker, All Rights Reserved

A Centenary Celebration

Designed By Dorothy Baker

Inner Circle Applique

LECIEN

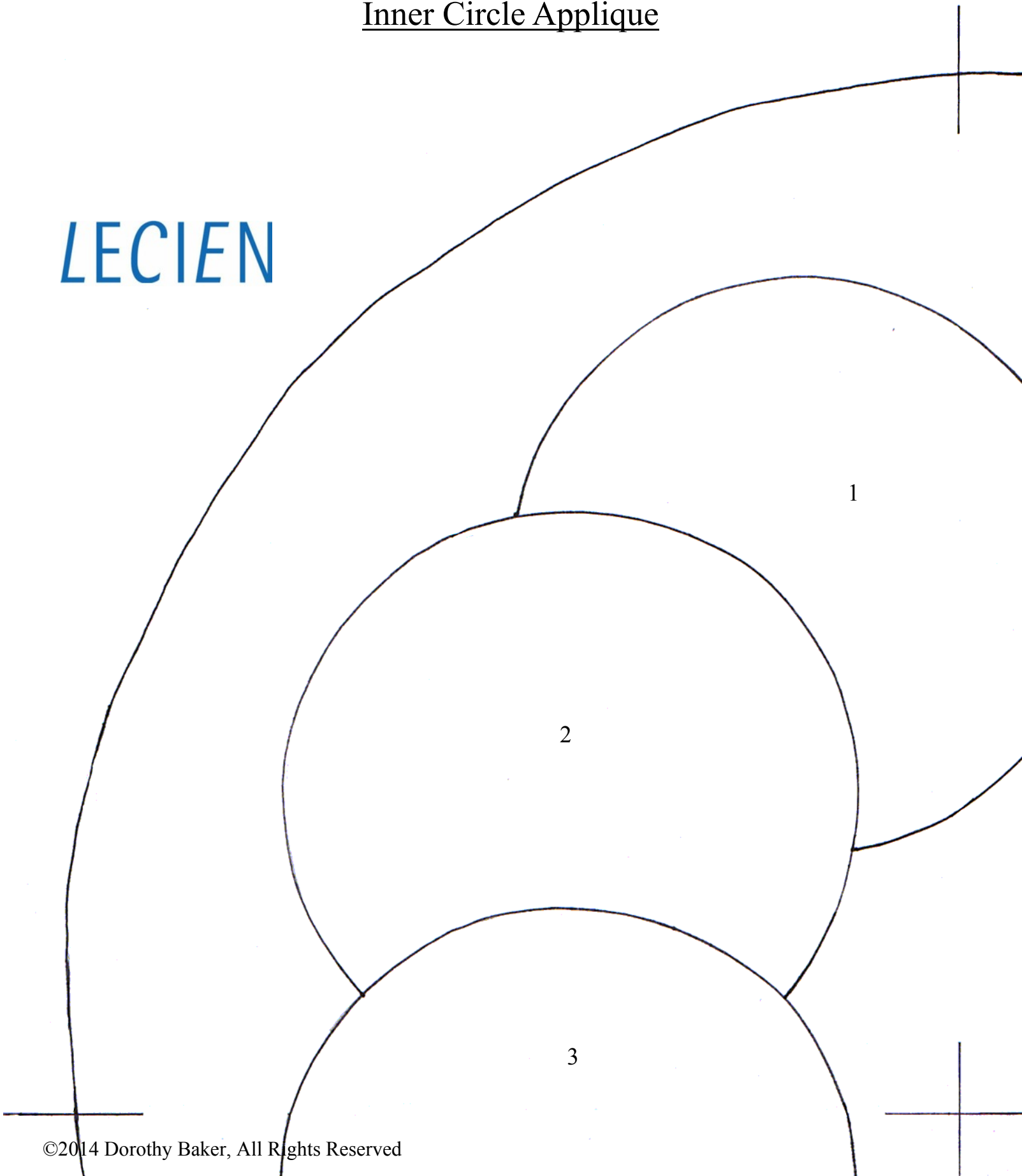

Inner Circle Applique

LECIEN

** Leave Circle 1 unstitched
between ** until Circle 8
is in place.

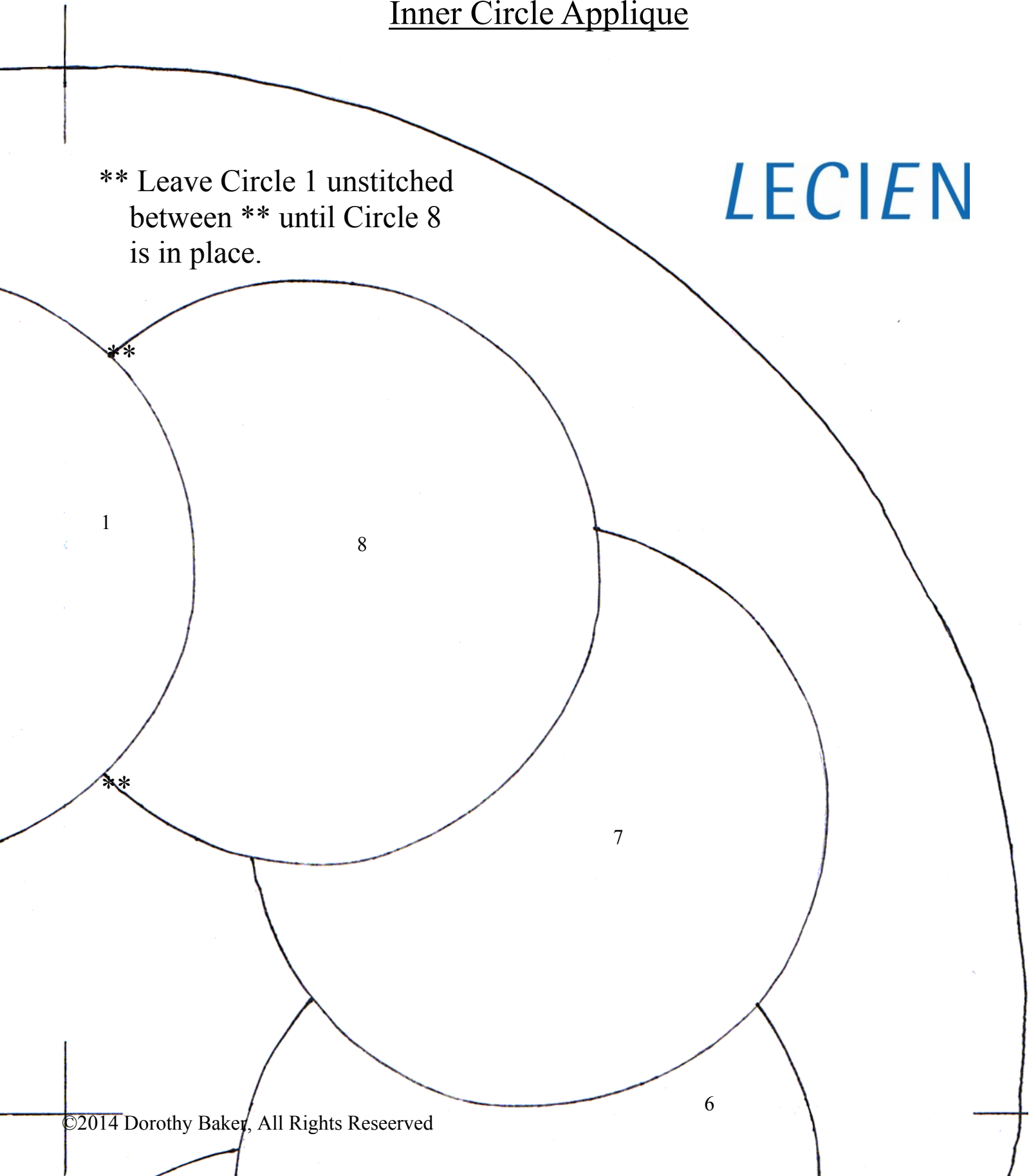

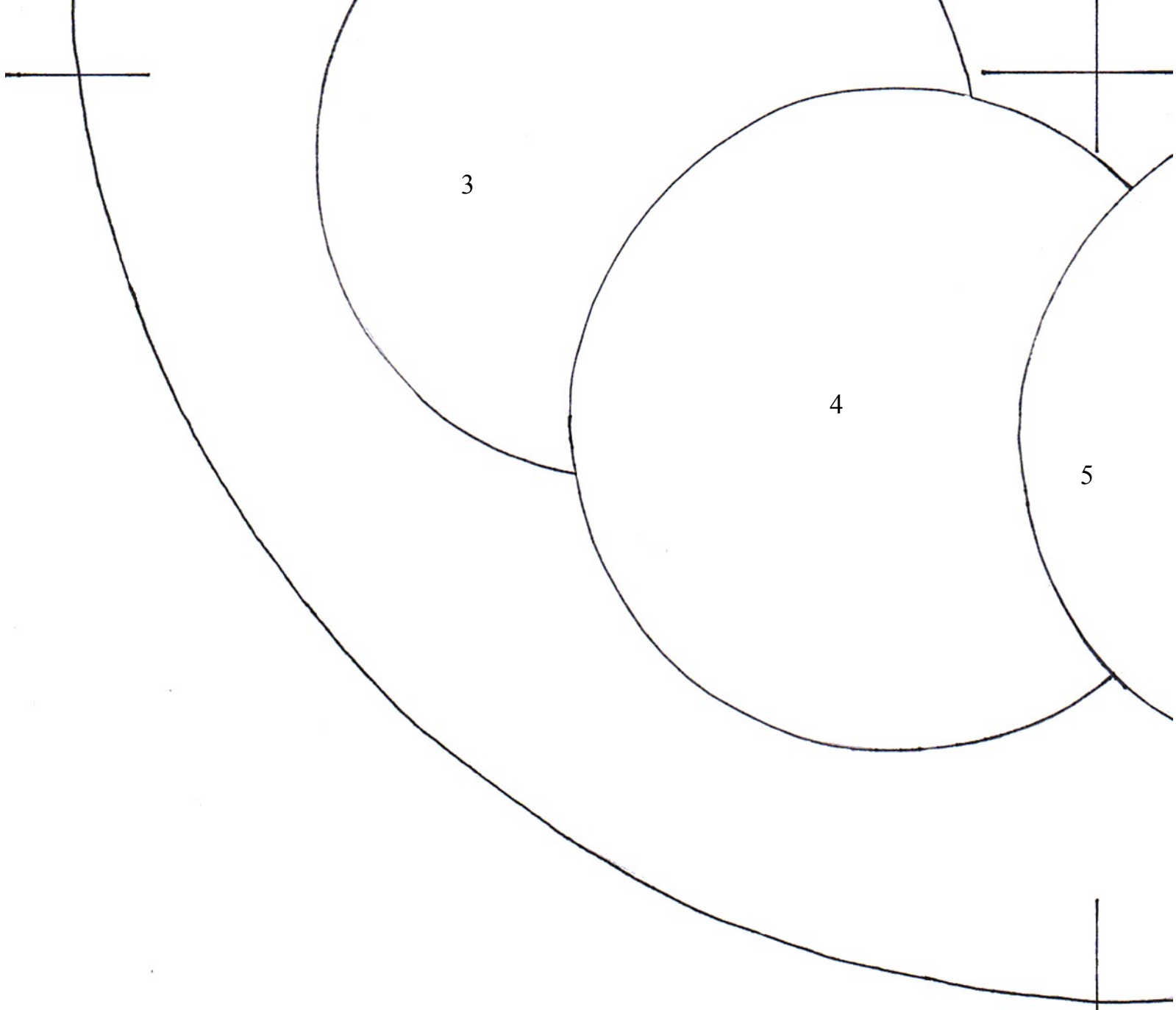

LECIEN

Inner Circle Applique

A Centenary Celebration

Designed By Dorothy Baker

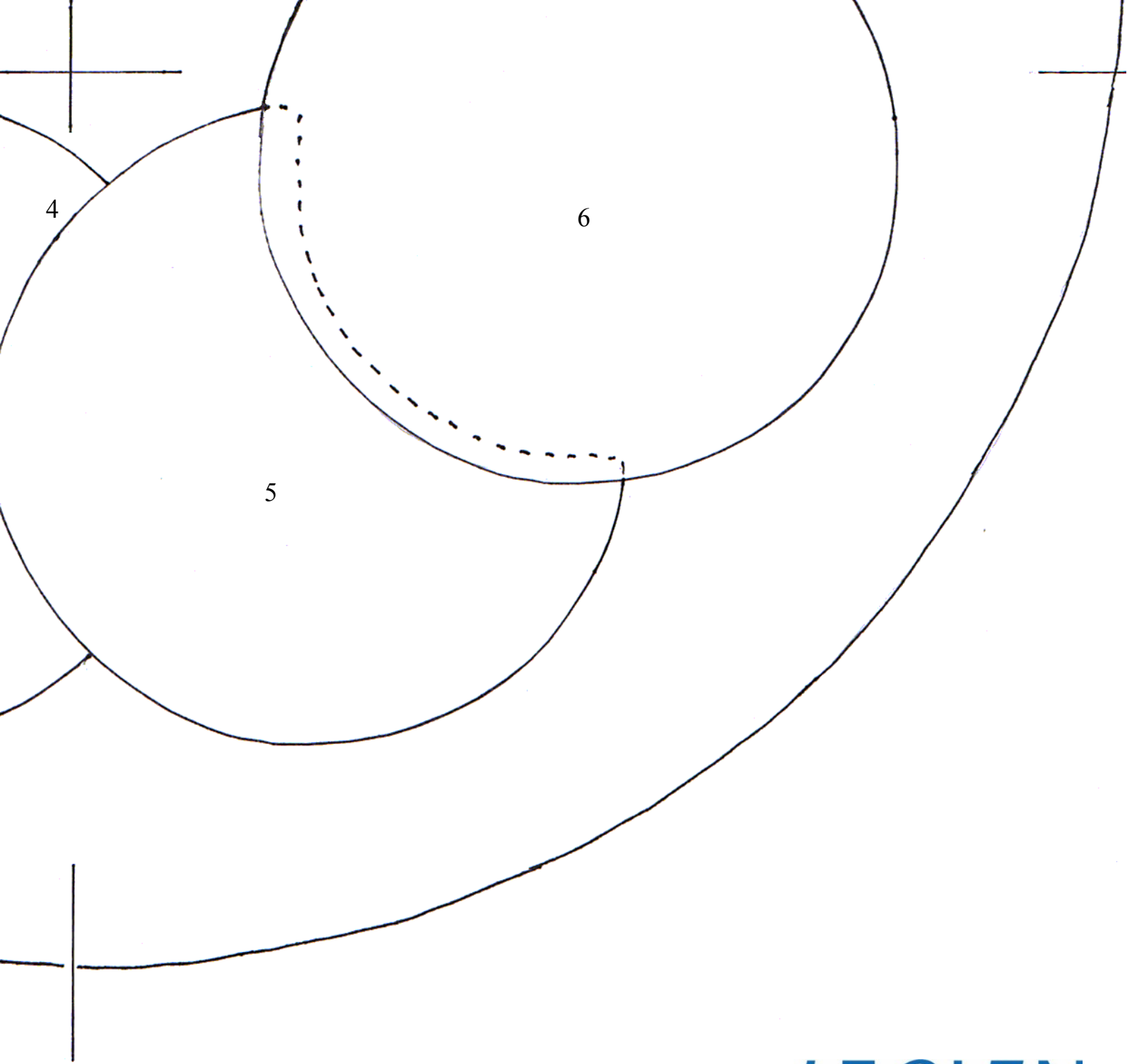

LECIEN

Inner Circle Applique

A Centenary Celebration

Designed By Dorothy Baker

A Centenary Celebration

Designed By Dorothy Baker

Circle Templates

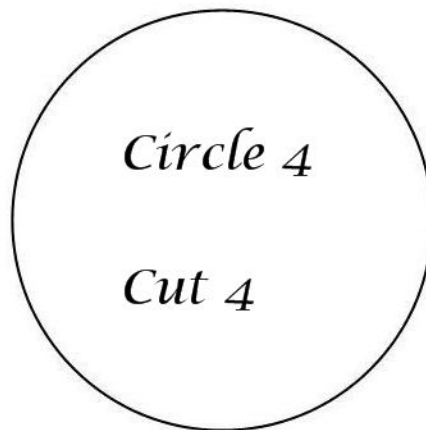
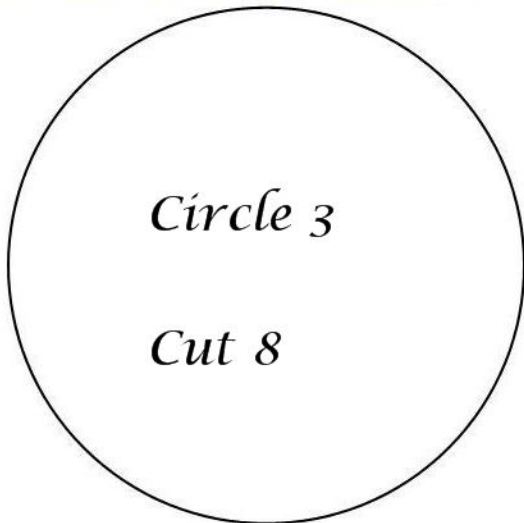
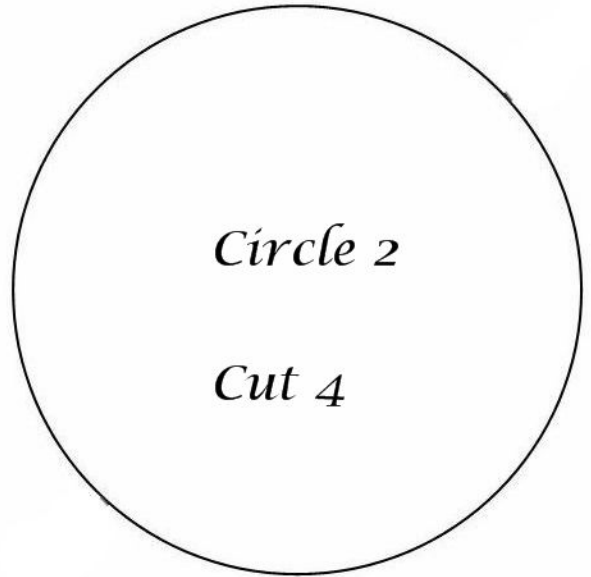
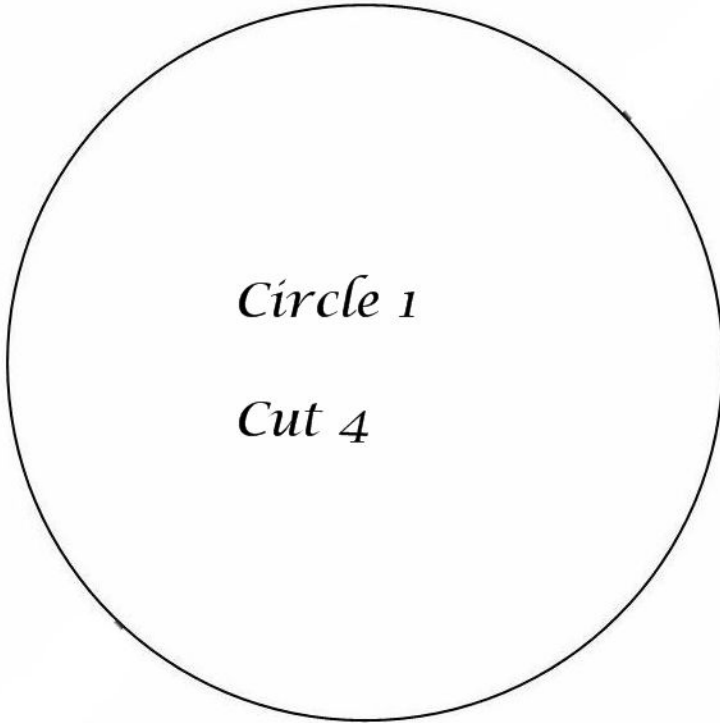

Border Applique

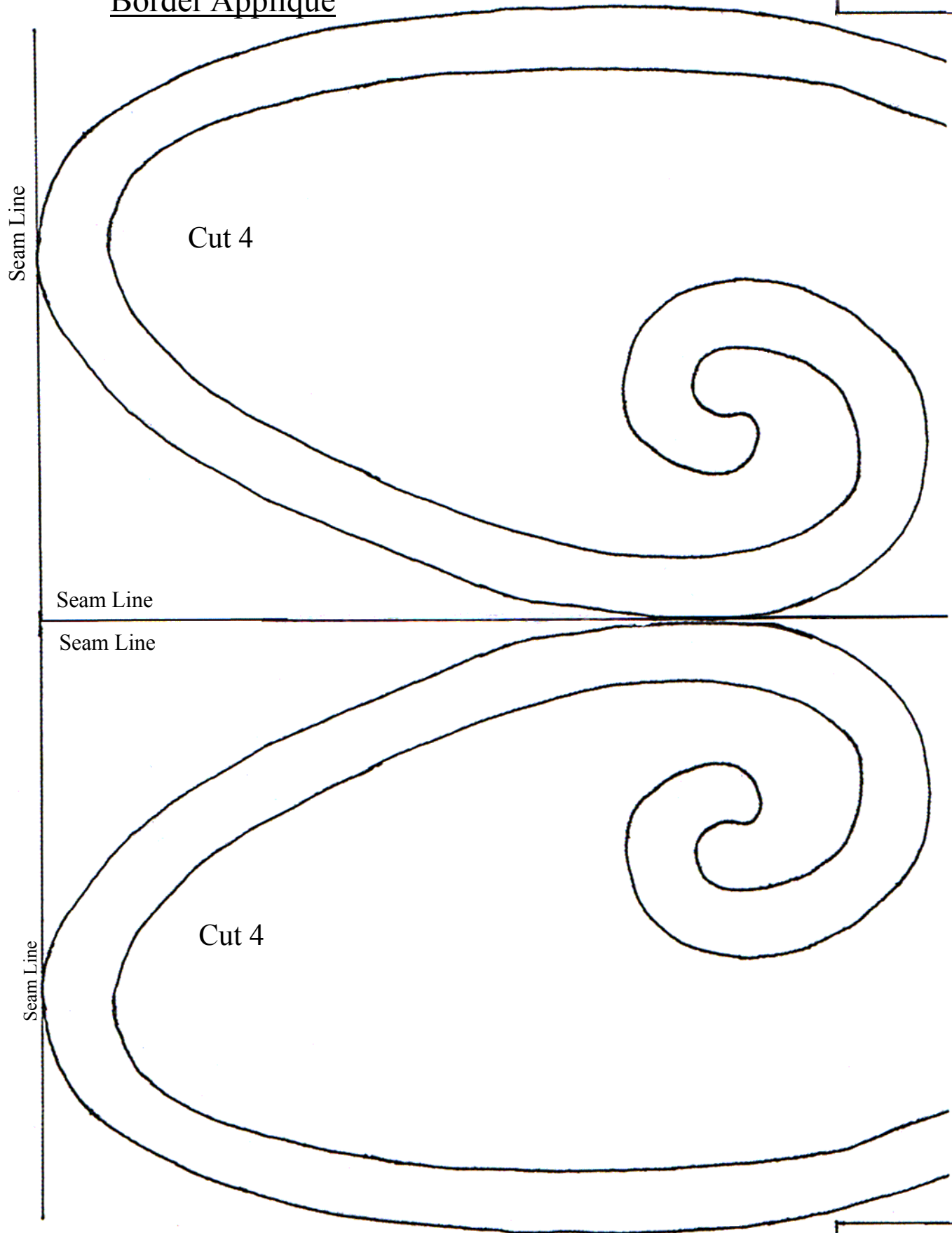

A Centenary Celebration

Designed by Dorothy Baker

Border Applique

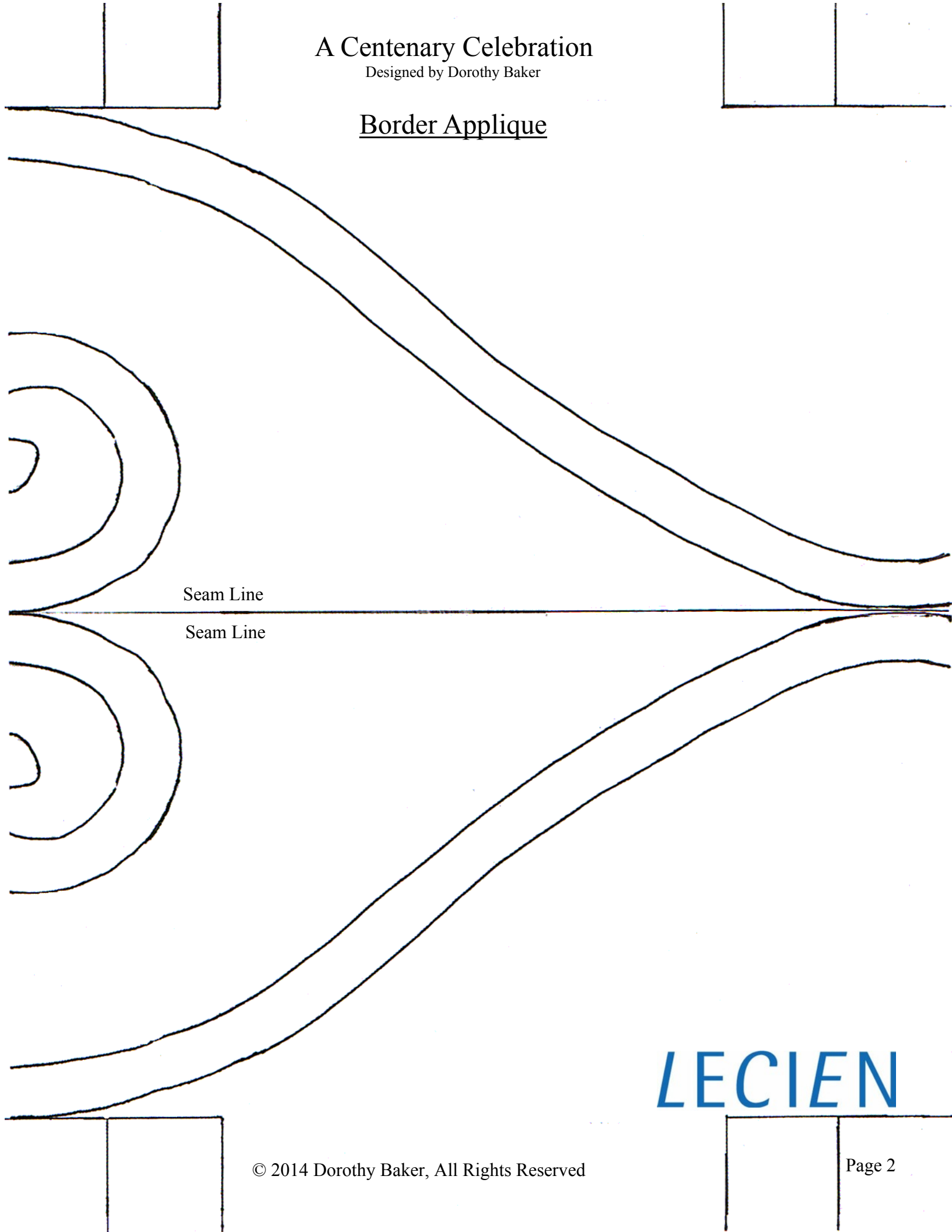

Seam Line

Seam Line

LECIEN

A Centenary Celebration

Designed by Dorothy Baker

Border Applique

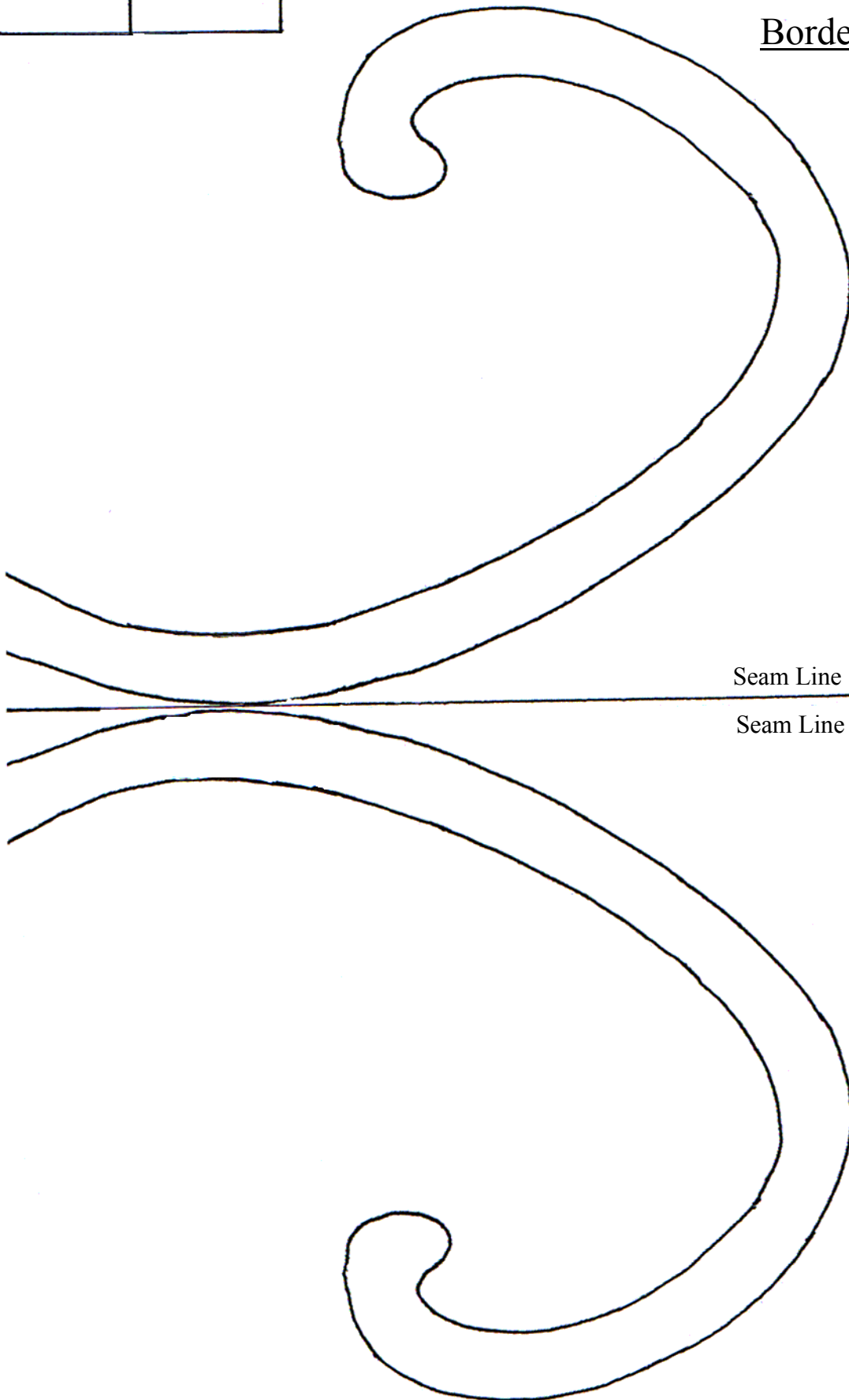

Seam Line

Seam Line

LECIEN